

IX100/202

Retail Printing Scales

The stylish IX series printing scales offer an outstanding range of features at the lowest price available.

- **Most economical scale in its class**
- **Network up to 9 scales**
- **Fast loading printer with take up spool**
- **Customer Ready (CR) Software** allows for easy setup and programming
- **Legal for Trade**



IX100/202 Retail Printing Scales

Designed to suit small independents and convenience stores, the IX series meets the essential needs of the local retailer at a very economical price. The IX features a compact footprint, simple set-up and configuration and new Customer Ready (CR) scale software — it's never been easier to maintain prices, labels and COOL standards.

FEATURES

- **Customer Ready (CR) Software** – Featuring 6 pre-programmed label formats for easy programming and set up.
- **Create Professional Labels** – Avoid purchasing costly preprinted labels with the memory-stored safe handling logo and the ability to add your own custom logo.
- **MX020 PC-to-scale Software** – Free, easy-to-use. Design your own labels and manage your PLU's all from the convenience of your PC.

DIMENSIONS

IX100

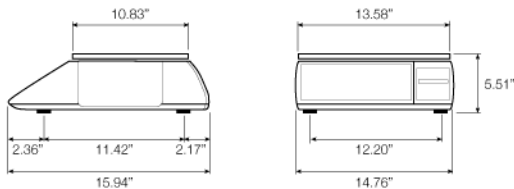

IX202

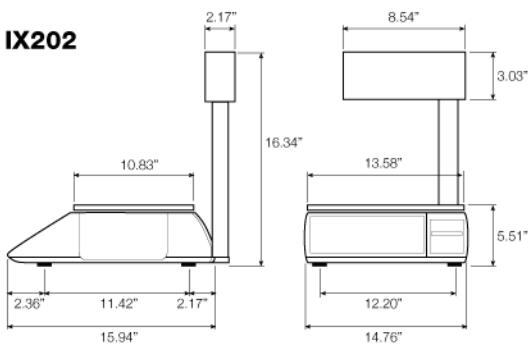

SPECIFICATIONS

- **Design**
IX100 – One-piece modular design.
IX202 – Customer tower display with extended keyboard.
- **Weighing Capacities Available**
30 lb x 0.01 lb (unit default)
15 kg x 5 g*, 12 lb x .002 lb*, 6kg x 2 g*
(*Requires configuration change and recalibration)
- **Display**
Easy to read, backlit LCD displays
- **Printer**
Easy-access, thermal label and receipt printer with take-up spool for backing paper:
2.2 in/second print speed.
3.94 in/100 mm diameter roll.
2.2 in/56 mm print width.
- **Keyboard**
Wipe clean keyboard with audible beep.
Fast number entry via cluster key arrangement.
Envelope pocket for keyboard overlay.
IX100 – 57 key keyboard. 34 direct PLUs.
IX202 – 79 key keyboard. 56 direct PLUs.
- **Data Memory**
Details of up to 1000 products/prices can be stored and recalled. Ability to add one custom logo.
- **Operators**
Up to eight operators can serve customers from any of the scales on the network.
- **Barcodes**
EAN 8/EAN 13/UPC 12/UPC 13
- **Interfaces**
RS485 scale interface as standard. Nine scales may be linked in a network. RS232 link to PC or barcode scanner. Cash drawer interface.
- **Management Reports**
PLU, group and operator totals.
- **Agency Approvals**
Legal for Trade, NTEP Class III
USA COC# 05-003
Canadian COC# AM-5639



Avery Berkel is a division of ITW Limited

AVERY BERKEL

1000 Armstrong Drive
Fairmont, MN, USA 56031

E-mail: sales@averyberkelusa.com
Web: www.averyberkelusa.com

Toll-Free: 800 237-1886
Fax: 800 237-2063