



Model 6712

portion control bench scale



portion control bench scale

NCI Model 6712 is designed for use in cafeterias, convenience stores, delicatessens, restaurants, candy shops or anywhere space is a premium.

Features & Benefits

- ◆ **Low Profile** Only 2.5" high.
- ◆ **Small Footprint** 10" x 10" platter.
- ◆ **Easy to Read** Six-digit LCD external display with large 0.5" characters, tactile keys, 7 ft. cable and Velcro™ for mounting.
- ◆ **Accurate and Reliable** Precision load cell and quality electronics ensure repeatable weight measurements and trouble-free operation.
- ◆ **Simple to Use** Reduces operator training time.
- ◆ **Interfaces** RS-232 only. NCI standard protocol only.
- ◆ **Auto Zero Tracking** Zero light indicator and manual control when out of range.
- ◆ **Quick Disconnects** Make all cable connections easily.
- ◆ **Construction** Stainless steel weighing area with full skirt around perimeter of base, except where connectors are located at rear of scale.

Options

- ◆ **Display Post** 12" high post for attachment to remote display.
- ◆ **International Power Supply** 230 VAC, 50 Hz power supply. Cable terminated with a universal connector.
- ◆ **Cables** Interface cables available for PCs and specific ECRs.
- ◆ **Display Brackets** Attach remote display to scale base.

Specifications

◆ Capacity and Resolution

Ounces
160 x 0.1

◆ Dimensions

Weigh Platter: 10" x 10" (254 mm x 254 mm)
Remote Display Enclosure: 5.8" W x 3.0" H x
1.4" D max (147 mm x 76 mm x 35 mm)
Adjustable Height: 2.5" – 3.0" (63 mm – 76 mm)

◆ Power

Input: Wall mount transformer 120 VAC
(+10% -15%)/ 60 Hz (±3 Hz)
Standard 3 wire with ground input
Output: 15 VDC @ 0.3 Amps minimum

◆ Operating Environment

41°F to 104°F (5°C to 40°C) (Class III device) 10% to 90% RH (non-condensing)

◆ Agency Approvals

Legal for Trade, NTEP Class III,
USA COC #00-096
Power Supply: UL Listed, CSA Certified

Dimensions

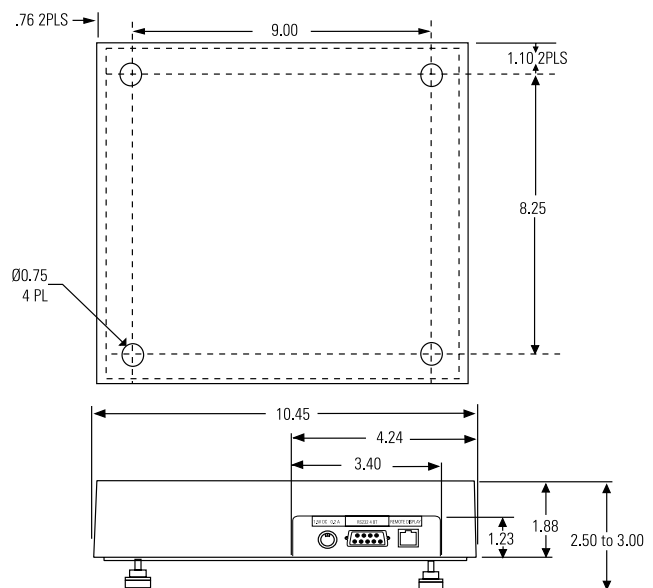

Avery Weigh-Tronix
(Retail North America)
1000 Armstrong Drive, Fairmont, MN 56031

PH Toll-Free: 800-237-1886
PH: 507-238-4461
FAX Toll-Free: 800-237-2063
FAX: 507-238-8756

E-mail: sales@AveryBerkelUSA.com
Internet: www.AveryBerkelUSA.com

Avery Weigh-Tronix

